

(19)



(11)

**EP 2 775 618 B1**

(12)

**EUROPEAN PATENT SPECIFICATION**

(45) Date of publication and mention of the grant of the patent:  
**18.01.2017 Bulletin 2017/03**

(51) Int Cl.:  
**H03K 3/84 (2006.01)**

(21) Application number: **12844933.7**

(86) International application number:  
**PCT/MX2012/000108**

(22) Date of filing: **01.11.2012**

(87) International publication number:  
**WO 2013/066143 (10.05.2013 Gazette 2013/19)**

(54) **RECONFIGURABLE MULTIVIBRATOR ELEMENT BASED ON CHAOS CONTROL**

AUF CHAOS-STEUERUNG BASIERENDES REKONFIGURIERBARES MULTIVIBRATORELEMENT  
ÉLÉMENT MULTIVIBRATEUR RECONFIGURABLE REPOSANT SUR LE CONTRÔLE DE CHAOS

(84) Designated Contracting States:  
**AL AT BE BG CH CY CZ DE DK EE ES FI FR GB GR HR HU IE IS IT LI LT LU LV MC MK MT NL NO PL PT RO RS SE SI SK SM TR**

• **FERMAT FLORES, Alejandro Ricardo**  
**C.P. 78290 San Luis Potosí (MX)**

(30) Priority: **01.11.2011 US 201161554187 P**

(74) Representative: **Jeannet, Olivier**  
**JEANNET & Associés**  
**26 Quai Claude Bernard**  
**69007 Lyon (FR)**

(43) Date of publication of application:  
**10.09.2014 Bulletin 2014/37**

(56) References cited:  
**DE-A1-102004 033 596 US-A- 3 253 156**  
**US-A1- 2003 067 336 US-A1- 2003 117 222**

(73) Proprietor: **Instituto Potosino de Investigacion Cientifica Y Tecnologica AC.**  
**78216 San Luis Potosí, S.L.P. (MX)**

• **CAFAGNA D ET AL: "Chaos-based computation via chua's circuit: parallel computing with application to the SR flip-flop", SIGNALS, CIRCUITS AND SYSTEMS, 2005. ISSCS 2005. INTERNATIONAL SYMPOSI UM ON IASI, ROMANIA JULY 14-15, 2005, PISCATAWAY, NJ, USA, IEEE, vol. 2, 14 July 2005 (2005-07-14), pages 749-752, XP010838103, ISBN: 978-0-7803-9029-4**

(72) Inventors:  
• **CAMPOS CANTON, Eric**  
**C.P. 78433 Soledad de Graziano Sánchez, S.L.P. (MX)**  
• **CAMPOS CANTON, Isaac**  
**C.P. 37910 San Luis de la Paz, Guanajuato (MX)**  
• **BARAJAS RAMIREZ, Juan Gonzalo**  
**C.P. 78309 San Luis Potosí (MX)**

**EP 2 775 618 B1**

Note: Within nine months of the publication of the mention of the grant of the European patent in the European Patent Bulletin, any person may give notice to the European Patent Office of opposition to that patent, in accordance with the Implementing Regulations. Notice of opposition shall not be deemed to have been filed until the opposition fee has been paid. (Art. 99(1) European Patent Convention).

**Description**

[0001] This application claims the benefit of priority to U.S. Provisional Application No. 61/554,187 filed November 01, 2011.

5

**Field of the invention**

[0002] The present invention relates to the field of reconfigurable structures and, more particularly, reconfigurable multivibrator electronic devices. As an underlying principle, this invention uses the dynamical richness of nonlinear (chaotic) systems to provide different alternatives or embodiments of multivibrators. Where a nonlinear oscillator circuit, a simple input circuit, and a comparator function (output circuit) are made to operate in astable, monostable or bistable mode.

10

**Background of invention**

[0003] Chaos is known to be useful. In fact, under certain conditions, it is a desirable feature of systems and circuits. The dynamical richness of chaotic behavior has significant potential applications to real-world problems, including secure communications, persistent excitation, information processing and incryption, to mention but a few (Ott, 2002 "Chaos in Dynamical Systems (Cambridge University Press, UK); Strogatz, S.H. 2001 "Nonlinear Dynamics, and Chaos: with applications to physics, biology, chemistry, and engineering (Westview Press, USA)); Tam et al., 2007 "Communications with Chaos: Multiple access techniques and performance (Elsevier Science Press, Great Britain)). In particular, the present invention uses chaos theory to design a reconfigurable multivibrator element in order to have different configurations in an all-in-one circuit.

15

20

[0004] A multivibrator circuit is a simple two-state system that has only one of three possible configurations, these are:

25

(i) Astable multivibrator, in this configuration, both states of the system are unstable. As a consequence, the output of the circuit spends a given amount of time in one state, and then in the other, moving back and forth from one to the other in a continuously repeated cycle. Usually, this configuration is used to generate sequences and pulses with a given frequency and width, see for example patents JP53085479, US4191927.

30

(ii) Monostable multivibrator, in this configuration, one state of the circuit is stable while the other is unstable. As such, the system may spend some time in the unstable state, but eventually will move into the stable state and remain there afterwards. This configuration can be used, for instance, to define a time-period of activity measured from an event, for example in JP57044768, US4430682 monostable multivibrators are used in motor timing.

35

(iii) Bistable multivibrator, in this configuration both states are stable. This implies that the circuit remains in its current state, until being forced to change to the other by an external event or input. A multivibrator system in bistable configuration can be used as a fundamental building block of a register or memory device, for example in US patents 4081840 and 4191927, a bistable multivibrator is used as part of a switching device.

[0005] There is great interest in developing new working paradigms to complement and even replace current statically configurable architectures. One of the newest ideas is chaos computing which focuses on the development of devices with dynamic logic architecture and employs nonlinear or chaotic elements in logic operations. Application of chaos computing requires the development of dynamic logic gates (also called logic cells) that are able to change their response according to threshold reference signals and offset signals in order to produce different logic gates. These dynamic logic gates would support development of logic chips for next generation computers. Current inventions related to logic gates that exploit features of nonlinear dynamic systems through their electronic implementations are, for example, US Patents 8091062, 7973566, 7924059, 7863937, 7415683, 7096437, 7453285, 7925814, 7925131 and US patent application 2010/0219858. These inventions make use of chaotic computing architectures based on nonlinear elements, while the present invention discloses reconfigurable multivibrator using a nonlinear oscillator.

40

45

[0006] Reconfigurable structures based on chaos have been investigated for a long time, with significant results, such as: [Cafagna, D. & Grassi, G. 2005. "Chaos-based computation via Chua's circuit: Parallel computing with application to the SR flip-flop," Int. Symp. Sign. Circuits Syst. 2, 749-752.] where the chaotic Chua's circuit is used to obtain two logic gates from two state variables, from those chaos-based logic they implemented two NOR gates and build a standard flip-flop device. Alternative realizations of chaos-based logic gate have been reported [Sinha, S. & Ditto, W. 1998 "Dynamics based computations," Phys. Rev. Lett. 81, 2156-2159.; Murali K., Sudeshna S. 2003 "Experimental realization of chaos control by thresholding", Physical Review E., vol. 68, Jul. 14, 2003; Campos-Cantón E., J. G. Barajas-Ramírez, G. Solís-Perales, R. Femat, 2010, "Multiscroll attractors by switching systems". CHAOS, 20: 013116]. With these logic gates is possible to build just a static bistable multivibrator.

50

55

[0007] Different methods for the construction of multivibrators have been disclosed, for example US patents 6281732, 4301427, and GB1416931 describe constructions of astable, monostable and bistable multivibrators based on stabilized

amplifiers, mosfets and inverters. However, unlike the present invention these multivibrators have fixed configurations, without the possibility of reconfiguration. In many applications of multivibrators more than one configuration is required, for example in devices for measurement and control of temperature, acoustic, and motor timing (see patents US4081840, US731082, JP53085479). In these inventions it is compulsory to combine more than one multivibrator configuration.  
 5 The reconfigurable multivibrator provided in the present invention discloses a single device to obtain an all-in-one multivibrator configuration (monostable, astable, and bistable).

**Summary of the invention**

10 **[0008]** US Patent US 3 253 156 discloses a system that generates nonlinear behavior but this behavior is far away to be chaotic, nonlinear behavior does not imply chaos. The nonlinear behavior is yielded by a resistance device with three regions, two of them  $c_1$  and  $c_2$  are positive resistances separated by an intervening region  $c_n$  of negative resistance (col. 2 lines 63-66) with a region of discontinuity in its current-voltage characteristic. (col. 1 lines 16-17). The negative region is bounded by positive resistances (col. 1 lines 21-24). The input block consists on an excitation source (fig. 1 ref "S") without possibility to accept the logic entries (00, 01, 10 and 11) and the output block is only a wire connected  
 15 with an external device (fig. 1 ref "U"). Now then, the instant invention discloses a circuit which always presents three unstable equilibrium points named saddle points and generates self-oscillations with periodic or chaotic behavior.

**[0009]** The instant application discloses and claims a dynamically reconfigurable multivibrator element, comprising: an input block coupled to a nonlinear chaotic system with a control input that adjust the parameters in order to change a desirable multivibrator configuration and coupled to an output block; wherein the nonlinear chaotic system is a Piecewise-linear (PWL) chaotic system and wherein the output block comprises at least one comparator circuit.

**[0010]** In said dynamically reconfigurable multivibrator element the adjustment of the parameters allows to get the three different multivibrator configurations, astable, bistable and monostable. Furthermore, wherein the dynamically reconfigurable multivibrator element is set to bistable configuration becomes the embodiment of a full SR flip-flop. wherein the full SR flip-flop accepts all the logic inputs (S,R): (0,0), (0,1), (1,0) and (1,1) and responds as  $(Q_{n+1})$ :  $Q_n$ , 0,1,and  $Q_n$ , respectively.

**[0011]** Also, said dynamically reconfigurable multivibrator element, when is set to astable configuration becomes the embodiment of a pulse generator with irregular period when the nonlinear element is oscillating chaotically or regular pulses when is oscillating into a limit cycle.

30 **[0012]** In a further embodiment, said dynamically reconfigurable multivibrator element, when is set to monostable configuration becomes unstable in the state logic zero and stable in the state logic one.

**[0013]** As a particular embodiment said dynamically reconfigurable multivibrator element, comprises an input block, a piecewise-linear (PWL) chaotic system with a control input that adjusts the parameters in order to change a desirable multivibrator configuration, and an output block with at least one comparator circuit.

35 Also, it is described an claimed a SR flip-flop device, comprising the above mentioned dynamically reconfigurable multivibrator elements.

**[0014]** Finally a pulse generator device is described, comprising the above disclosed dynamically reconfigurable multivibrator elements.

40 **Brief description of the drawings**

**[0015]**

45 FIG. 1 is a block diagram of a reconfigurable dynamic multivibrator device using an input circuit, a nonlinear oscillator and comparator function in the output circuit.

50 FIG. 2 is a circuit schematic of the reconfigurable multivibrator device of Fig. 1 according to one embodiment of the present invention; The elements 202, 204, 206, 208, 210, 212, 214, 216, 218, 220, 222, 224, 226, 228, 230, 232 and 234 constitute the input block, the output block is comprised by the elements 236, 238, 240, 242, 244 and 246, and the nonlinear oscillator is made up by the elements 248, 250, 252, 254, 256, 258, 260, 262, 264, 266, 268, 270, 272, 274, 276, 278 and 280.

55 FIG. 3 is a series of timing graph illustrating timing sequences of implementations of a representative bistable multivibrator configuration formed in accordance with the inventive arrangements disclosed herein that generates a full RS flip-flop.

FIG. 4 is a series of timing graph illustrating timing sequences of implementations of an astable multivibrator configuration formed in accordance with the arrangements by using the dynamically reconfigurable multivibrator element

disclosed in the instant invention.

FIG. 5 is a series of timing graph illustrating timing sequences of implementations of a representative monostable multivibrator configuration formed in accordance with the inventive arrangements disclosed herein.

5

### Detailed description of the invention

[0016] The instant invention comprises a dynamically reconfigurable multivibrator element based on nonlinear (chaotic) dynamics which through a parameter modulating control specially designed to operate as one of the three multivibrator configurations, namely, astable, monostable or bistable multivibrator circuits. The advantage of the element is that a single device (all-in-one) is capable of carrying out the three configurations without additional multivibrator elements.

10

[0017] As for the scope of the invention, the term element should be understood as a circuit that can be incorporated to a larger system, device or circuit suitable for the purposes of the invention.

15

[0018] The invention comprises nonlinear dynamics of a Piecewise Linear (PWL) system used to provide the three different multivibrator configurations. Structurally PWL systems are very simple, consisting of linear descriptions for each partition of their phase space. This simplicity makes them particularly well-suited for electronic implementations, e.g. via operational amplifiers. On the other hand, they can produce dynamical behaviors that range from stable fixed points to multiscroll chaotic attractors. As described in [Campos-Cantón E., J. G. Barajas-Ramírez, G. Solís-Perales, R. Femat, 2010, "Multiscroll attractors by switching systems". CHAOS, 20: 013116], different dynamical regimes can be imposed on the solutions of a PWL system by properly tuning the system's parameters. In this way, an analogy between the three multivibrator configurations and the dynamical regimes of a PWL system can be obtained as follows:

20

(i) Astable multivibrator. By applying parameter modulation control, a PWL system can be made to have a double-scroll chaotic attractor with a basin of attraction covering its entire domain. By associating to each scroll a different output state, as the trajectories of the system move along the chaotic attractor, the output state will continuously switch from one output state to the other, which corresponds to the behavior of an astable multivibrator. It is noteworthy that since the transitions between the output states occurs as the trajectory moves along the chaotic attractor, the transitions will occur at irregular times and not with a fixed period.

25

(ii) Monostable multivibrator. A controlled PWL system can be made to have a single-scroll chaotic attractor for its entire domain. By dividing the domain along the center axis with the single-scroll attractor contained in one side, it is possible to associate an output state to the empty part of the domain and the other output state to the single-scroll attractor. Then, as the trajectories move from the empty half of the domain towards the single-scroll attractor, the output state will be at one value for a while, and when the trajectory reaches the attractor, the output will switch to the other state and remain at that value from that moment on. In this way, the monostable multivibrator behavior is obtained from a PWL system via chaos control.

30

35

(iii) Bistable multivibrator. Under appropriate parameter modulating control a PWL system can be made to have two different stable single-scroll attractors located each side of the center axis of the domain. When there are two stable chaotic attractors and it is possible to generate only one of them by means of changing the initial conditions, it is said that the system exhibits bistable chaos. In this case the trajectories will follow only one of the attractors according to their initial conditions. That is, in bistable chaos, each attractor has its own distinct basin of attraction. Then, associating each output state to the basins of attraction of each single-scroll chaotic attractor, if an initial condition is set to one of the attractors the output state will remain at that value from that moment on. However, if the initial condition is set to the opposite side, the other output state will be shown from that moment onwards. As such, the behavior of the bistable multivibrator is obtained from the controlled PWL system.

40

45

[0019] Thus, the present invention provides a reconfigurable multivibrator that can be configured to function as any of a variety of different multivibrators such as a bistable multivibrator, a monostable multivibrator and an astable multivibrator. The functionality of the reconfigurable multivibrator can be altered by changing one or more parameters to the nonlinear oscillator. The reconfigurable multivibrator can function, for example, as one type of multivibrator, such as a bistable multivibrator, and during operation be instructed to begin operating or functioning as another type of multivibrator, such as an astable multivibrator or monostable multivibrator or combinations thereof. Applications are illustrated herein below by designing a circuit that functions as a pulse generator and a full S-R flip flop device based on the all-in-one reconfigurable multivibrator element.

50

55

[0020] Table I below illustrates a truth table of basic operations. For example, column 3 illustrates the function of a bistable multivibrator given inputs (S,R), column 4 shows the function of an astable multivibrator given inputs (S,R), and column 5 shows the function of a monostable multivibrator given inputs (S,R).

TABLE 1

1	2	3	4	5
S	R	Bistable $Q_n$	Astable $Q_n$	Monostable $Q_n$
0	0	$Q_{n-1}$	Free running	Free running
0	1	0	Not allowed	Not allowed
1	0	1	Not allowed	Not allowed
1	1	$Q_{n-1}$	Free running	Free running

5

10

15

20

25

30

35

40

45

50

55

[0021] Figure 1 is a schematic diagram illustrating a high level circuit architecture **100** for a reconfigurable multivibrator in accordance with the present invention. Therefore, this Figure 1 discloses the essential technical characteristic of the invention, and should be taken as the main principle of the same. As shown, the reconfigurable multivibrator can include a nonlinear oscillator **110**, a parameters controller **112**, an input circuit **106**, and an output circuit **116**. The parameters controller provides a tuning of parameters that change the stability of the nonlinear oscillator. The input block can receive the inputs signals **S 102** and **R 104**, when **S** and **R** are equal the signal **108** is null but when they are different then signal **108** forced the nonlinear oscillator **110**. The output block **116** receives the signal **114** which is compared with a reference signal in order to generate a logic zero or logic one that are given as the output **Q 118**.

[0022] The operation of the nonlinear oscillator **110** according to the present invention can be described by the mathematical model as follows:

$$\begin{pmatrix} \dot{x}_1 \\ \dot{x}_2 \\ \dot{x}_3 \end{pmatrix} = \begin{pmatrix} \alpha(x_2 - x_1 - f(x_1)) \\ x_1 - x_2 + x_3 \\ -\beta x_2 + \gamma x_3 \end{pmatrix}$$

where  $f(x_1)$  is a nonlinear negative resistor which is described as

$$f(x_1) = \begin{cases} b_1 x_1 - c_1, & \text{if } x_1 > 1; \\ \alpha x_1, & \text{if } |x_1| \leq 1; \\ b_2 x_1 + c_2, & \text{if } x_1 < -1; \end{cases}$$

with  $c_t = b_t - a, t = 1, 2$ . Thus, the nonlinear oscillator **110** can be implemented as a three dimensional Chua's system. Given a dynamics  $(\dot{x}_1, \dot{x}_2, \dot{x}_3)^T$  corresponding to a physical device, the values of parameters and initial state satisfying the conditions derived from the truth table to be implemented must be determined. Still, those skilled in the art will recognize that other functions also can be used, including, but not limited to, discrete time chaotic functions.

EXAMPLES.

[0023] As a preferred embodiment, that should be taken as a work example but not limiting the scope of the invention, Figure 2 represents schematic diagram illustrating an exemplary circuit implementation of the dynamically reconfigurable multivibrator element **100** depicted in Figure 1. The operation of the input block according to the present invention may be described as follows: there are two inputs **202 (S)** and **204 (R)** that are introduced to the system by the resistors **214 (R<sub>209</sub>)** and **206 (R<sub>206</sub>)**. The input **204 (R)** is passed through inverting amplifier given by the operational amplifier **210 (U<sub>2</sub>)** and the resistor **206 (R<sub>6</sub>)** and **208 (R<sub>7</sub>)**. The output of the operational amplifier **216 (U<sub>3</sub>)** is the voltage **262 (V<sub>1</sub>)** which is added with the input signal **202 (S)** and the output of operational amplifier **210 (-R)** through the resistors **212 (R<sub>8</sub>)**, **214 (R<sub>9</sub>)**, **218 (R<sub>10</sub>)** and **220 (R<sub>11</sub>)** and the operational amplifier **222 (U<sub>4</sub>)** by means of inverting adder. Thus the output of **222 (V<sub>a</sub>)** is  $R \cdot S - V_1$  (**204-202-262**) due to all the values of the resistor of the input block are equal to 1 k $\Omega$ , except for the resistor **234 (R<sub>14</sub>)**, which is set to 100 k $\Omega$ . The voltage **224 (V<sub>a</sub>)** is passed through the inverting amplifier given by the resistors **226 (R<sub>12</sub>)** and **228 (R<sub>13</sub>)**, and the operational amplifier **230 (U<sub>5</sub>)**, generating the voltage **232 (V<sub>n</sub>)**. The voltage **232 (V<sub>n</sub>)** is given by  $V_1 + S - R$ , always that the inputs **202** and **204** are equal ( $S=R$ ) the voltage **232 (V<sub>n</sub>)** is equal to the voltage **262 (V<sub>1</sub>)** and the current through the resistor **234 (R<sub>14</sub>)** is zero.

[0024] The operation of the output block according to the present invention may be described as follows: the input

voltage for this block is **262** ( $V_1$ ) that is passed through a buffer **236** ( $U_6$ ) and after a low pass filter comprising resistor **238** ( $R_{15}$ ) and the capacitor **240** ( $C_3$ ), this signal is passed by a buffer **242** ( $U_7$ ) and a comparator **244** ( $U_8$ ), generating the output signal **246** ( $Q$ ).

[0025] The nonlinear oscillator has the following relationship between the electronic components in FIG. 2 and the parameters of the mathematical model are:

$$\alpha = \frac{C_2}{C_1}, \beta = \frac{C_2 R_0^2}{L}, \gamma = \frac{C_2 R_0 r}{L}, \alpha = -\frac{R_0 R_2}{R_1 R_3}, b_1 = -\frac{R_0 R_2}{R_1 R_3} + \frac{R_0}{R_4},$$

$$b_2 = -\frac{R_0 R_2}{R_1 R_3} + \frac{R_0}{R_5},$$

where the capacitor **260**  $C_1 = 100nF$ , the capacitor **254**  $C_2 = 1\mu F$ , the inductor **250**  $L = 67.1 mH$  with internal resistance **248**  $r = 2.57 \Omega$ , the resistors **270** ( $R_2$ ) and **268** ( $R_3$ ) equal to  $220\Omega$ . The resistors **258** ( $R_0$ ), **272** ( $R_1$ ), **276** ( $R_4$ ) and **280** ( $R_5$ ) are  $5 k\Omega$  potentiometers. The potentiometer **258**  $R_0$  is tuned to  $1003 \Omega$  the others according to the Table 2. The parameter  $b_1$  is active when the diode **274**  $D_1$  is forward bias voltage and the parameter  $b_2$  is active when the diode **278**  $D_2$  is forward bias voltage.

TABLE 2

	Bistable	Astable	Monostable
$R_1$ tune to	$884 \Omega$	$825 \Omega$	$884 \Omega$
$R_4$ tune to	$4.062 k\Omega$	$3.058 k\Omega$	$4.062 k\Omega$
$R_5$ tune to	$4.062 k\Omega$	$3.058 k\Omega$	$3.515 k\Omega$

[0026] The bistable form of multivibrator illustrated in Figure 2 is controlled by the inputs according to the table 1 and the potentiometers **272** ( $R_1$ ), **276** ( $R_4$ ) and **280** ( $R_5$ ) tune according to the table 2.

[0027] When the dynamically multivibrator element is configured as bistable, it becomes part, for example, of a full SR flip-flop device. Thus, Figure 3 is a series of timing graph illustrating timing sequences of implementations of a representative bistable multivibrator configuration formed in accordance with the arrangements disclosed in a specific embodiment of the invention, which generates a full SR flip-flop. The timing sequences of the exemplary bistable multivibrator implementation, from top to bottom, represent: (1) first input S; (2) second input R; and (3) the output Q.

[0028] An advantage of the bistable form of the multivibrator according to the present invention is that all the entries are allowed, i.e., the system is determined for a particular entry (S,R)=(1,1); as is shown in the table 1.

[0029] The astable form of multivibrator illustrated in Figure 2 is free-running when the potentiometers **272** ( $R_1$ ), **276** ( $R_4$ ) and **280** ( $R_5$ ) are tuned according to the table 2, and the inputs are set at zero volts.

[0030] When the dynamically multivibrator element is configured as astable, it becomes part of a, for example, a noise generator. Therefore, Figure 4 is a series of timing graph illustrating timing sequences of implementations of a representative astable multivibrator configuration formed in accordance with a particular example of the dynamically reconfigurable multivibrator element of the instant invention. This multivibrator generates an aperiodic rectangular output wave and also can generate periodic rectangular output wave. The input circuitry can be omitted, since the astable multivibrator is shown in a free-running form, so the line from the resistor **234** to the node **262** ( $V_1$ ) can be shut off.

[0031] An advantage of the astable form of the multivibrator according to the present invention provides for equal rise and fall times on the square wave, as well as symmetrical on and off periods. Furthermore, due to its nonlinear dynamics and the possibility to produce chaos is possible to generate irregular or chaotic square wave that can be used as a noise generator.

[0032] The monostable form of multivibrator illustrated in Figure 2 is free-running when the potentiometers **272** ( $R_1$ ), **276** ( $R_4$ ) and **280** ( $R_6$ ) are tuned according to Table 2, and the inputs are set at zero volts.

[0033] In such monostable configuration, Figure 5 represents a series of timing graph illustrating timing sequences of implementations of a representative monostable multivibrator configuration formed according to the dynamically reconfigurable multivibrator element disclosed above.

[0034] As a consequence, one multivibrator, a set of multivibrators, or all of the multivibrators within the system can change functionality according to data provided as in Table 2, which parameters can change according to the application of the dynamically reconfigurable multivibrator element using an example that has incorporated specific analog compo-

nents. Those skilled in the art will recognize that such components have been provided for purposes of illustration only. Therefore, any variety of different components, whether functional equivalents, variants, or alternatives of the analog components or of the higher level components (i.e. of Figure 1) disclosed herein, can be used and are within the scope of the invention. As such, the invention is not limited to the use of a particular component or set of components.

5 **[0035]** In light of the above description, a dynamically reconfigurable multivibrator element is designed by adding modulation parameters which modify the stability properties of the linear subsystems. Because the chaos generation is exploited, the multivibrator element incorporates dynamical features onto the a logic-gate architecture.

**[0036]** Thus, the proposed dynamical logic structure is more adaptable than static logic-gates, as it is reconfigurable by parametric modulation. The reconfiguration allows us to achieve distinct tasks with the same circuit. that is, the proposed architecture might serve as a component of general purpose computing devices with a flexible structure. As a consequence of the parametric modulation, diverse scrolls are generated or inhibited around the equilibrium points of the continuously connected sections of the nonlinear (chaotic) system (such as the PWL system).

15 **Claims**

1. A dynamically reconfigurable multivibrator element comprising: an input block (106) coupled to a nonlinear chaotic system (110) with a control input (112) that adjust parameters in order to change a desirable multivibrator configuration and coupled to an output block (116); **characterized in that** the adjustment of the parameters allows to get the three different multivibrator configurations (112), astable, bistable and monostable; and wherein the nonlinear chaotic system (110) is a Piecewise-linear (PWL) chaotic system.
2. The dynamically reconfigurable multivibrator element according to claim 1, wherein the output block (116) 236, 238, 240, 242 or 244) comprises at least one comparator circuit.
3. The dynamically reconfigurable multivibrator element according to claim 1, wherein is set to bistable configuration becomes the embodiment of a full SR flip flop.
4. The dynamically reconfigurable multivibrator element according to claim 3, wherein the full SR flip flop accepts all the logic inputs (S,R): (0,0), (0,1), (1,0) and (1,1) and responds as (Q<sub>n+1</sub>): Q<sub>n</sub>, 0,1, and Q<sub>n</sub>, respectively.
5. The dynamically reconfigurable multivibrator element according to claim 1, wherein when is set to astable configuration becomes the embodiment of a pulse generator with irregular period when the nonlinear element is oscillating chaotically or regular pulses when is oscillating into a limit cycle.
6. The dynamically reconfigurable multivibrator element according to claim 1, wherein when is set to monostable configuration becomes unstable in the state logic zero and stable in the state logic one.

40 **Patentansprüche**

1. Dynamisch rekonfigurierbares Multivibratorelement, das aufweist : einen Eingangsblock (106), der mit einem nicht-linearen chaotischen System (110) mit einem Steuereingang (112) gekoppelt ist, der Parameter anpasst, um eine erwünschte Multivibratorkonfiguration zu ändern und mit einem Ausgangsblock (116) gekoppelt, **dadurch gekennzeichnet, daß** die Anpassung der Parameter ermöglicht, die drei verschiedenen Multivibratorkonfigurationen (112), astabil, bistabil und monostabil zu erhalten ; und wobei das nichtlineare chaotische System (110) ein teilweises lineares (PWL) chaotisches System ist.
2. Dynamisch rekonfigurierbares Multivibratorelement nach Anspruch 1, **dadurch gekennzeichnet, daß** der Ausgangsblock (116) 236, 238, 240, 242 oder 244) mindestens eine Vergleicherschaltung aufweist.
3. Dynamisch rekonfigurierbares Multivibratorelement nach Anspruch 1, **dadurch gekennzeichnet, daß** wenn auf bistabile Konfiguration gelegt ist, wird die Ausführungsform eines vollen SR-Flipflops.
4. Dynamisch rekonfigurierbares Multivibratorelement nach Anspruch 3, **dadurch gekennzeichnet, daß** das volle SR-Flipflop alle logischen Eingänge (S, R): (0,0), (0, 1), (1,0) und (1, 1) akzeptiert und als (Q<sub>n</sub> + 1): Q<sub>n</sub>, 0, 1 und Q<sub>n</sub> beziehungsweise antwortet.

5. Dynamisch rekonfigurierbares Multivibratorelement nach Anspruch 1, **dadurch gekennzeichnet, daß** wenn auf astabile Konfiguration gelegt ist, wird die Ausführungsform eines Impulsgenerators mit unregelmäßiger Periode, wenn das nichtlineare Element chaotisch oszilliert, oder regelmäßige Impulse, wenn es in einen Grenzyklus oszilliert.
- 5 6. Dynamisch rekonfigurierbares Multivibratorelement nach Anspruch 1, **dadurch gekennzeichnet, daß** wenn auf monostabile Konfiguration gelegt ist, wird in der Zustandslogik Null instabil und in der Zustandslogik 1 stabil.

### Revendications

10

1. Un élément multivibrateur reconfigurable dynamiquement, comprenant: un bloc d'entrée (106) relié à un système chaotique non-linéaire (110) avec une entrée de commande (112) qui règle des paramètres afin de changer une configuration de multivibrateur souhaitable et qui est reliée à un bloc de sortie (116) ; **caractérisé en ce que** le réglage des paramètres permet d'obtenir les trois configurations de multivibrateur (112) différentes : astable, bistable et monostable; et dans lequel le système chaotique non-linéaire (110) est un système chaotique à éléments linéaires (PWL).
- 15
2. L'élément multivibrateur reconfigurable dynamiquement selon la revendication 1, dans lequel le bloc de sortie (116, 236, 238, 240, 242 ou 244) comprend au moins un circuit comparateur.
- 20
3. L'élément multivibrateur reconfigurable dynamiquement selon la revendication 1, **caractérisé en ce qu'**il est mis en configuration bistable et devient le mode de réalisation d'une bascule SR complète.
- 25
4. L'élément multivibrateur reconfigurable dynamiquement selon la revendication 3, dans lequel la bascule SR complète accepte toutes les entrées logiques (S, R) : (0,0), (0, 1), (1, 0) et (1, 1) et répond (Qn + 1) : Qn, 0,1, et Qn, respectivement.
- 30
5. L'élément multivibrateur reconfigurable dynamiquement selon la revendication 1, **caractérisé en ce que**, lorsqu'il est mis en configuration astable, il devient le mode de réalisation d'un générateur d'impulsions à période irrégulière lorsque l'élément non linéaire oscille chaotiquement ou en impulsions régulières lorsqu'il oscille dans un cycle limite.
- 35
6. L'élément multivibrateur reconfigurable dynamiquement selon la revendication 1, **caractérisé en ce que**, lorsqu'il est mis en configuration monostable, il devient instable dans l'état de logique zéro et stable dans l'état de logique 1.

35

40

45

50

55



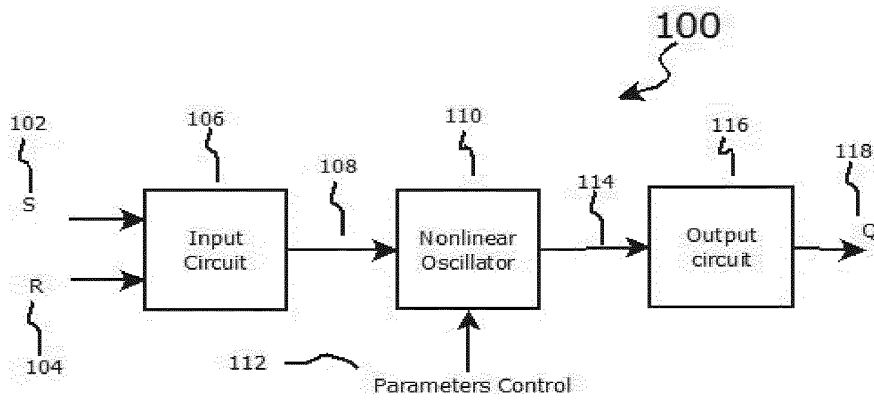

Fig. 1

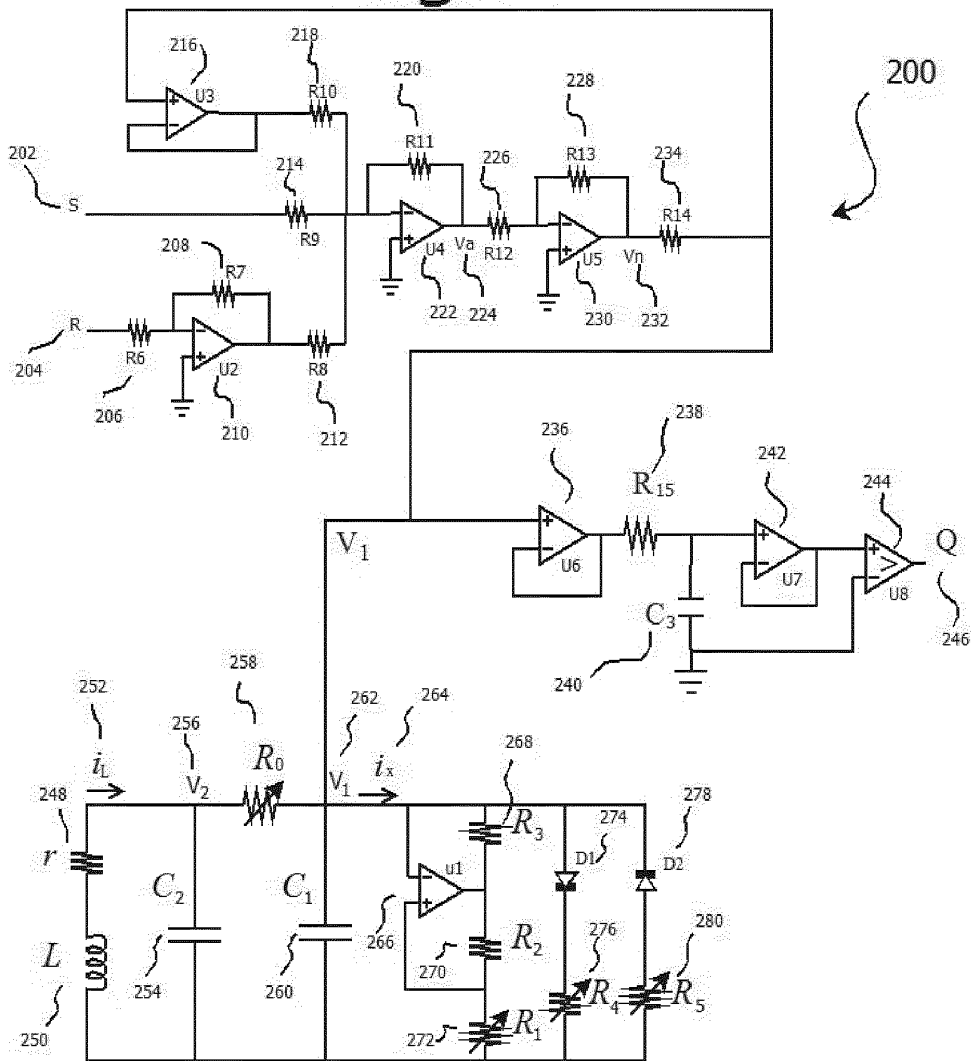

Fig. 2

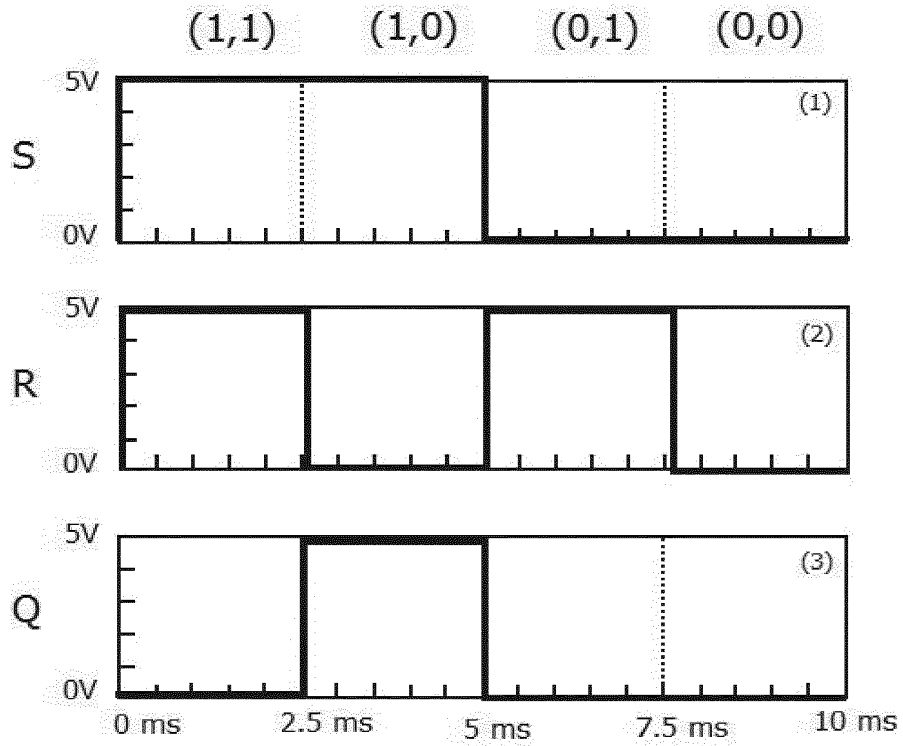

Fig. 3

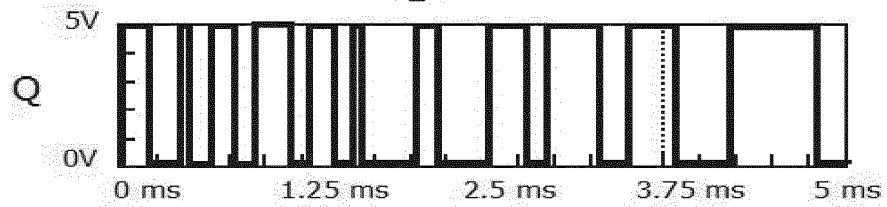

Fig. 4

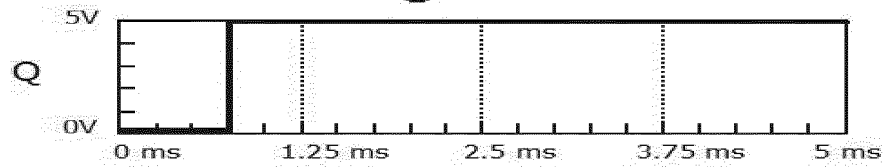

Fig. 5

REFERENCES CITED IN THE DESCRIPTION

*This list of references cited by the applicant is for the reader's convenience only. It does not form part of the European patent document. Even though great care has been taken in compiling the references, errors or omissions cannot be excluded and the EPO disclaims all liability in this regard.*

Patent documents cited in the description

- US 61554187 A [0001]
- JP 53085479 B [0004] [0007]
- US 4191927 A [0004]
- JP 57044768 B [0004]
- US 4430682 A [0004]
- US 8091062 B [0005]
- US 7973566 B [0005]
- US 7924059 B [0005]
- US 7863937 B [0005]
- US 7415683 B [0005]
- US 7096437 B [0005]
- US 7453285 B [0005]
- US 7925814 B [0005]
- US 7925131 B [0005]
- US 20100219858 A [0005]
- US 6281732 B [0007]
- US 4301427 A [0007]
- GB 1416931 A [0007]
- US 4081840 A [0007]
- US 731082 A [0007]
- US 3253156 A [0008]

Non-patent literature cited in the description

- **OTT**. Chaos in Dynamical Systems. Cambridge University Press, 2002 [0003]
- **STROGATZ, S.H.** Nonlinear Dynamics, and Chaos: with applications to physics, biology, chemistry, and engineering. Westview Press, 2001 [0003]
- **TAM et al.** Communications with Chaos: Multiple access techniques and performance. Elsevier Science Press, 2007 [0003]
- **CAFAGNA, D. ; GRASSI, G.** Chaos-based computation via Chua's circuit: Parallel computing with application to the SR flip-flop. *Int. Symp. Sign. Circuits Syst.*, 2005, vol. 2, 749-752 [0006]
- **SINHA, S. ; DITTO, W.** Dynamics based computations. *Phys. Rev. Lett.*, 1998, vol. 81, 2156-2159 [0006]
- **MURALI K. ; SUDESHNA S.** Experimental realization of chaos control by thresholding. *Physical Review E.*, 14 July 2003, vol. 68 [0006]
- **CAMPOS-CANTÓN E. ; J. G. BARAJAS-RAMÍREZ ; G. SOLÍS-PERALES ; R. FEMAT.** Multiscroll attractors by switching systems. *CHAOS*, 2010, vol. 20, 013116 [0006] [0018]